

**Vorkammerbuchse**  
**Z13**  
*Melt chamber bushing*  
**Z13**



## Z13 Vorkammerbuchse

### Z13 Melt chamber bushing

Diese Vorkammerbuchse eignet sich für die MONOLITH® Düsen.  
 This melt chamber bushing is suitable for the MONOLITH® nozzles

#### HINWEISE:

- der Anspritzdurchmesser ist individuell festzulegen und in der Bestellbezeichnung zu ergänzen

#### NOTE:

- The gating diameter is to be defined individually and supplemented in the order designation

Typ 1  
 Type 1

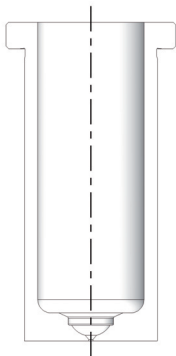

Bestell-Nr.		Z13-16	Z13-20	Z13-22	Z13-24	Z13-28
Order No.						
für Düse for nozzle		16,0	20,0	22,0	24,0	28,0
	d	28,5	33,0	37,0	39,0	43,0
	d1	21,0	25,0	28,0	30,0	34,0
	h1	5,0	5,0	8,0	8,0	8,0
	d2	Info zum Anspritz-Ø im Infocenter Information on the gating point dia. can be found in infocenter				
<b>L (Länge)</b> <i>L (lengths)</i>	40	•	•	•	•	
	50	•	•	•	•	
	60	•	•	•	•	•
	80	•	•	•	•	•
	100	•	•	•	•	•
	120	•	•	•	•	•
	140	•	•	•	•	•
	160			•	•	•
	180			•	•	•
	200					•
240					•	

## Z13 Einbauhinweise Vorkammerbuchse

### Z13 Installation instructions for melt chamber bushing

Variante MONOLITH®  
version MONOLITH®

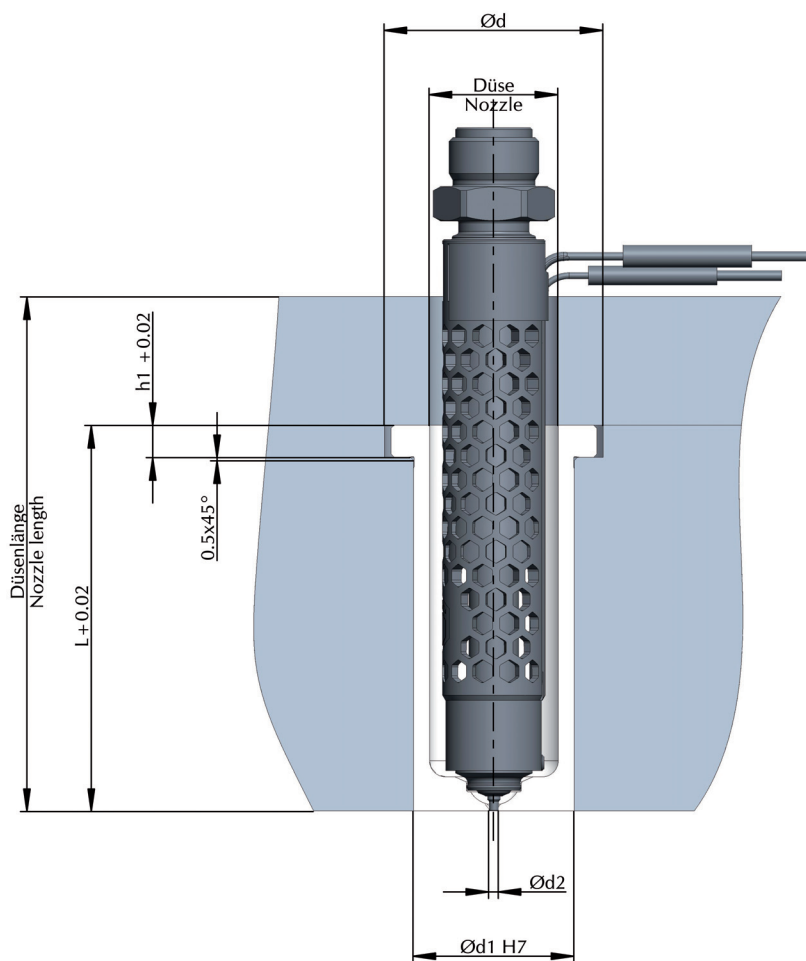

Alle Angaben in mm  
All specifications in mm

Oberfläche, wenn nicht anders angegeben: RA2,3 oder VDI3400 Ref.27  
Surface, if not specified otherwise: RA2.3 or VDI3400 Ref. 27

CAD-Daten zu unseren Standard-Produkten finden Sie in den üblichen Formaten unter [witoso.de](http://witoso.de)  
CAD data for our standard products can be found in common formats at [witoso.de](http://witoso.de).